

KOMATSU®

C144

Forestry Quality™

C144

HARVESTING HEAD



Uncompromising dependability and profitable

The head that never lets you down – not even in the most demanding and rough harvesting environments. This is our newly developed Komatsu C144.

Refusal to compromise is seen not the least in the entirely new 4 WD feed. The system's extra roller in the feed line, which complements the body roller and produces significantly higher feed force, is truly unique. This is especially noticeable on extremely coarse trees and difficult to delimb tops. Productivity is further enhanced with an entirely new Constant Cut cutting unit, including a new saw motor and bar mount. The Constant Cut function not only speeds cutting and increases dependability, it

also minimizes risks for chain shot and splitting.

The generous 40-degree tilt also does its part in raising production by enabling the fastest possible feed start. And the two front delimiting knives make quick work of even the most difficult delimiting tasks. At the same time, you'll gain terrific dependability and ease of service, in among other ways, through centralized lubrication points. An important quality factor is patented accurate and reliable length measuring. So if you want a head that offers maximum production every day and every shift – choose the Komatsu C144!

TECHNICAL DATA

C144

Komatsu C144 highlights

- New 4 WD with extra body roller produces significantly greater feed force
- New Constant Cut saw unit, new saw motor and new saw bar mount
- Constant Cut with constant 40 m/s (131 ft/s) chain speed – increases productivity and minimizes risks for chain shot and splitting
- Integrated saw valve enables exact control of the saw motor's flow needs
- Tilt angle of 40 degrees enables faster feed start/increased productivity
- Four hydraulic delimiting knives, with the two at the front providing more efficient delimiting of trees that are difficult to delimit
- Patented length measuring with exact measurement accuracy and high reliability thanks to non-contact signal transmission
- New hydraulic valve with improved access
- Hydraulics system with higher energy efficiency due to among other things, a new actively controlled feed-pressure valve
- Safe and simple service with centralized lubrication points

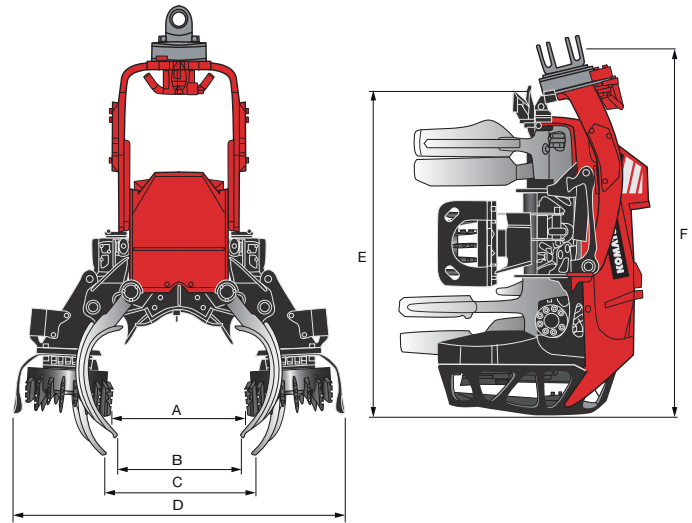

Dry weight:	from 1,400 kg (3,086 lb)
Feed speed:	0-5 m/s (0-16.4 ft/s)
Feed force, gross (roller motor dependent):	29.6 kN
Feed wheel type:	Steel rollers
Delimiting knives, max. number:	5
Delimiting diameter, tip-to-tip:	525 mm (20.7")
Bar:	82.5 cm (32.5")
Saw motor:	19 cm³/rev. (1.2 cu in/rev)
Felling diameter, theor. max:	710 mm (28")
Requisite max. hydraulic flow (roller motor dependent):	320 l/min (84.5 gpm)
Requisite max. hydraulic pressure:	28 MPa (4,061 psi)

A Roller opening, max.	750 mm (29.5")
B Opening upper knives, max.	660 mm (26")
C Opening lower knives, max.	800 mm (31.5")
D Width, max.	1,795 mm (70.7")
E Height to upper knife	1,600 mm (63")
F Height to rotator	1,770 mm (69.7")

NOTE: Only one of many possible configurations and the weight of the harvesting head depends on any optional equipment selected.

EQUIPMENT OPTIONS

Standard and extra equipment are market-dependent and vary between countries. Your sales representative has an up-to-date list of what is included.

Technical data/dimensions vary depending on optional equipment selected. Specifications and designs are subject to alteration without prior notice. Photos, diagrams, and sketches do not always show the standard model machine.

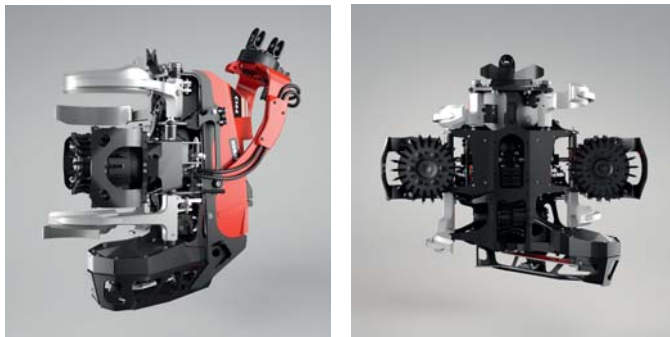

ZONE OF APPLICATION

